

DEMA® Olympian
 Rinse & Sanitizer Warewash Control
 O-RDV & O-RHV (Blue)
 O-SDV & O-SHV (Yellow)

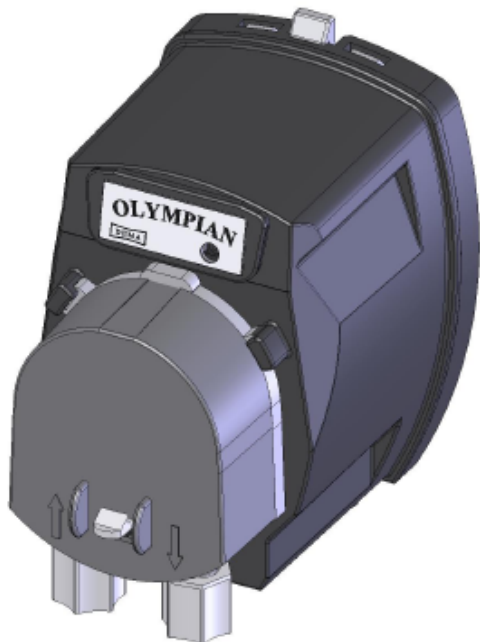

Please read all instructions before proceeding with the Olympian installation.

PURPOSE:

The Olympian™ rinse and sanitizer warewash systems control chemical delivery functions for door-type dish machines and similar warewash applications. They require an 81-245-1 Two Button Programmer (see below) to set up the initial programming. Only one Two Button Programmer is required as it can be used to program as many Olympian models as desired.

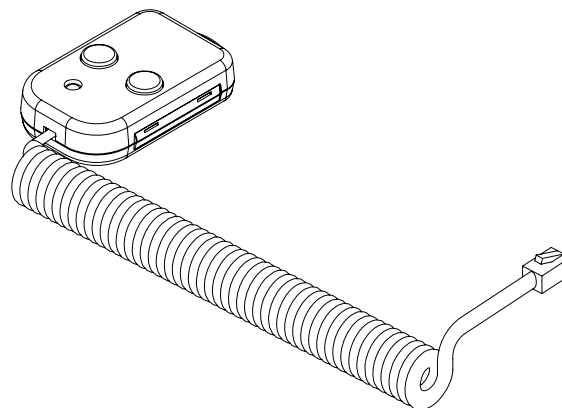

Power Specifications		
Model	Voltage	Current
O-RDV* O-SDV*	115/230V 50/60 HZ	0.5 A
O-RHV O-SHV	230V 50/60 HZ	0.5 A

81-245-1 TWO BUTTON PROGRAMMER
 (Optional; not included.)

*Factory set at 230V.

DEMA Engineering Company
 10020 Big Bend Blvd.
 St. Louis, MO 63122
 (800) 325-3362 or (314) 966-3533
 www.demaeng.com

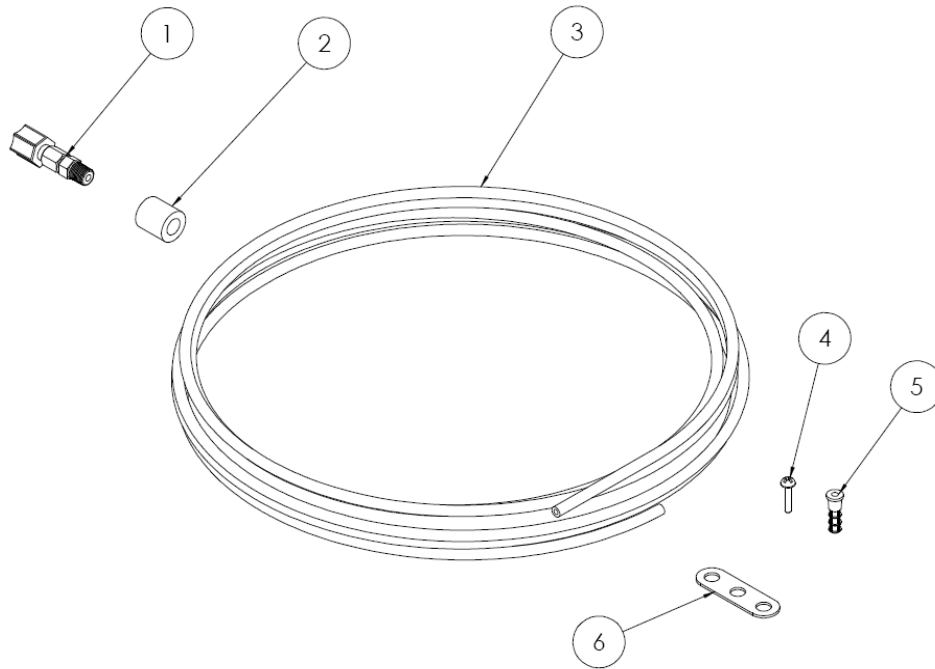

PARTS CHECKLIST BY OLYMPIAN MODEL

ITEM	PART NO.	DESCRIPTION	Blue - Rinse		Yellow - Sanitizer	
			O-RHV	O-RDV	O-SHV	O-SDV
1.	904-8T	Rinse – Injection Check Valve	1	1	-	-
	904-8P	Sanitizer – Injection Check Valve	-	-	1	1
2.	61-107-4	Ceramic Weight	1	1	1	1
3.	100-12SV1	Tubing Vinyl ¼”OD x 1/6”ID	1	1	1	1
4.	30-37	Screw	3	3	3	3
5.	66-121	Wall Anchor	3	3	3	3
6.	81-248-1	Weight Retainer	1	1	1	1

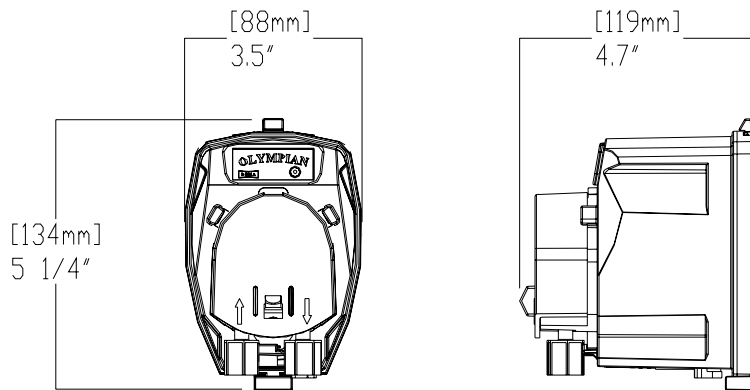

Shipping Weight: 2.85 lb (1.29 kg)

ELECTRICAL INSTALLATION:

All installations must be in accordance with city, county, parish, state, or provincial electrical codes and be performed by a certified electrician. For questions, please contact a local licensed electrical contractor.

1. All electrical power must be turned off to the dish or cleaning machine and any other circuit that is to be used for this installation. Lockout and tag procedures must be observed when installing this device. Never open the Olympian enclosure while power is applied. Signals may be active from the dish or cleaning machine, even with Olympian power turned off. Use appropriately rated insulated wiring, electrical fixtures, and other materials that meet all applicable electrical and building codes.
2. **O-RDV Controls Only:** This control has a switch to select the proper line voltage. The unit is factory set to 230VAC. To change the voltage to 115VAC, remove the back of the control. Move the switch from 230VAC to 115VAC as shown in Figure 1. Reinstall the back cover.
WARNING: This must be done *before* connecting power to the unit.
3. Connect to the appropriate power source.

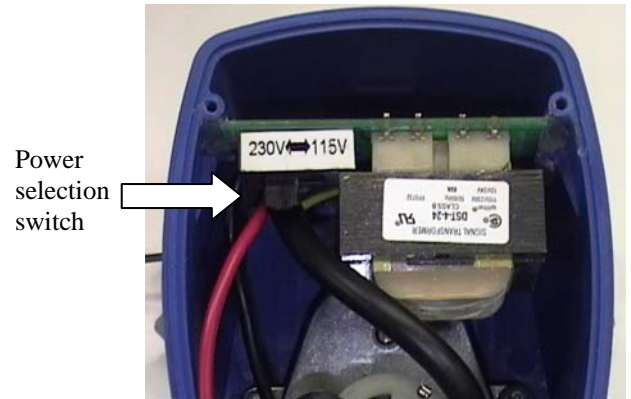

Figure 1. Input Voltage Switch

TUBING INSTALLATION:

1. Install weight and weight retainer as shown in Figure 2.
2. Place weight and retainer in chemical container.
3. Cut tubing to the appropriate length. Attach tubing to the pump inlet.
4. Attach outlet tubing to pump outlet and to dish or cleaning machine. Attach outlet tubing to injection check valve (904-8T or 904-8T).



Figure 2. Tubing, Weight, & Retainer

PROGRAMMING:

NOTE: Due to the short wash and rinse cycles, the programming of the unit may require several wash cycles.

Step 1: Apply power.

Step 2: Remove the cover and connect the Two Button Programmer as shown in Figure 3.



Figure 3. Programmer Installation

Step 3: Push either button on the programmer to toggle the LED to the desired program mode as shown in Figure 4. See below for the program mode.



Figure 4. Program Mode Selection

	Program Mode	LED Color	Description	Programming	Factory Default Settings
1	Delay	Yellow	Amount of time delay between power and pumping of rinse additive	Push both buttons to start delay time and both buttons to stop delay time	0 Seconds
2	Pump Speed	Green	Speed of pump	Push both buttons to enter programming mode. Push left button to reduce speed. Push right button to increase speed	100% (Maximum speed)
3	Rinse Limit	Red	Active = Pump will stop running after 18 seconds of power. Inactive = Pump will run until power is turned off.	Push either button to toggle the LED on the programmer. On = Activates rinse limit Off = Pump runs until power is turned off	Active

Rinse Limit Indicator
On = Limit is active
Off = Limit is inactive

Step 4: Push both buttons, simultaneously, to start programming the time or enter program mode.

Step 5: Push both buttons, simultaneously, to stop time or exit the program mode.

Step 6: Repeat steps 3-5 for each program mode.

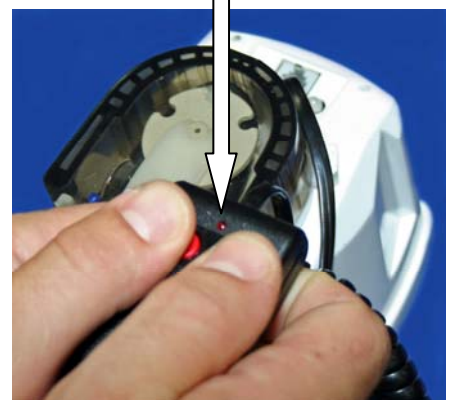
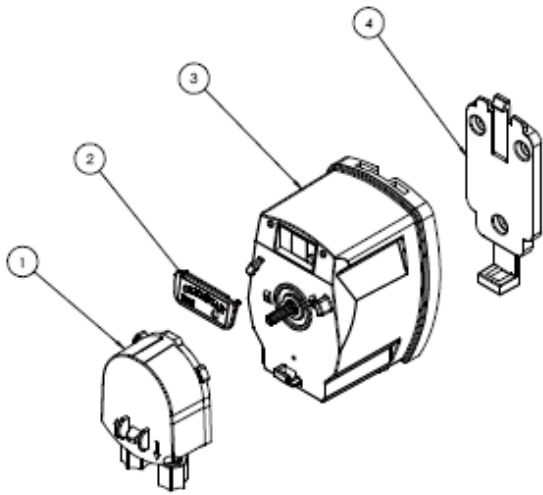
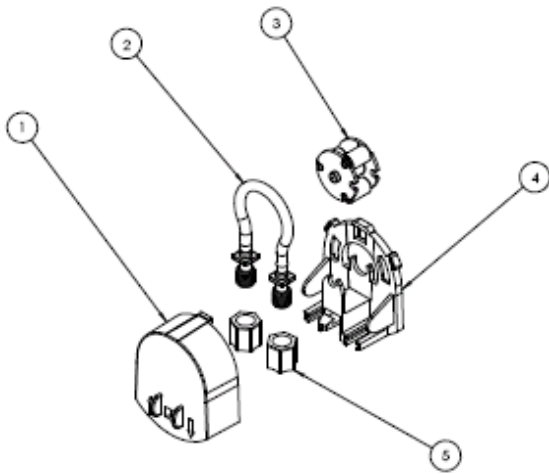

Figure 5. Programming Start / Stop

Step 7: After the Olympian Unit has been programmed with the desired values, remove the Two Button Programmer from the Olympian programming jack and replace the Olympian cover.



Replacement Parts			
Item	DEMA [®] P/N	Qty	Description
1	81-226-1	1	Rinse/Sanitize Pump Assembly
2		1	Cover with Label
3		1	Olympian Control (no pump included)
4	81-223-1	1	Mounting Bracket



Pump Replacement Parts			
Item	DEMA [®] P/N	Qty	Description
1	81-240-1	1	Pump Bore
2	81-231-2	1	Squeeze Tube Assembly
3	81-218-1	1	Roller Block Assembly - Rinse
4	81-240-2	1	Pump Base
5	80-67-13	2	Compression Fittings

Return Policy

No merchandise may be returned for credit without DEMA[®] Engineering Company's written permission. Return Merchandise Authorization (RMA) number required in advance of return.

Warranty

DEMA[®] products are warranted against defective material and workmanship under normal use and service for one year from the date of manufacture. This limited warranty does not apply to products that have a normal life shorter than one year or failure and damage caused by chemicals, corrosion, improper voltage supply, physical abuse or misapplication. Rubber and synthetic parts such as "O"-rings, diaphragms, squeeze tubing and gaskets are considered expendable and are not covered under warranty. This warranty is extended only to the original buyer of DEMA[®] products. If products are altered or repaired without prior approval of DEMA[®], this warranty will be void.

Defective units or parts should be returned to the factory with transportation prepaid. If inspection shows them to be defective, they will be repaired or replaced without charge. F.O.B. factory DEMA[®] assumes no liability for damages. Return merchandise authorization number to return units for repair or replacement must be granted in advance of return.